

# 2" GUNITE JET INSTALLATION INSTRUCTIONS



25580-200, 25580-290 Complete Assy for 2" S Water x 1-1/2" S Air

25581-200, 25581-290 Complete Assy for 1-1/2" Spg (1" S) Water x 1" Spg (1/2" S) Air

*Gunite Jet Body Assemblies include Body, Wall Fitting, & Threaded Ring. PVC Schedule 40 Pipe is not included  
Standard Niche is only included with 25580-290 and 25581-290*

## INSTALLATION PROCEDURES & PRESSURE TESTING

1. Run ties through holes in the Jet Body braces, and attach to the rebar
2. Glue the 2" PVC pipe into the Jet Body. Cap the other end of the 2" pipe for pressure testing.
3. After the pool is gunited, chip out the wall around the pipe to provide enough area for the Niche. Cut the 2" pipe so that the Niche will be at the finished level of the wall. Glue the Niche into the 2" pipe.
4. Glue the threaded ring onto a piece of 1" pipe. Thread into the jet. Draw a line even with the opening of the niche; remove the 1" pipe. Measure back 4-1/4" and cut the 1" pipe.
5. Glue the Wall Fitting to the other end of the 1" pipe. Lubricate the o-ring. Insert this assembly back through the Niche and the 2" pipe and thread clockwise into the Jet Body. Tighten with the Gunite Jet Tool. Pressure testing can now be done by threading the Gunite Jet Wrench into the Wall Fitting.
6. After pressure testing, remove the Gunite Plug. Choose the desired jet face internal and the desired Jet Orifice. Insert the Jet Orifice into the back of the Diffuser, long tube first. Insert the Butterfly. Thread the jet internal into the Wall Fitting until the stop.

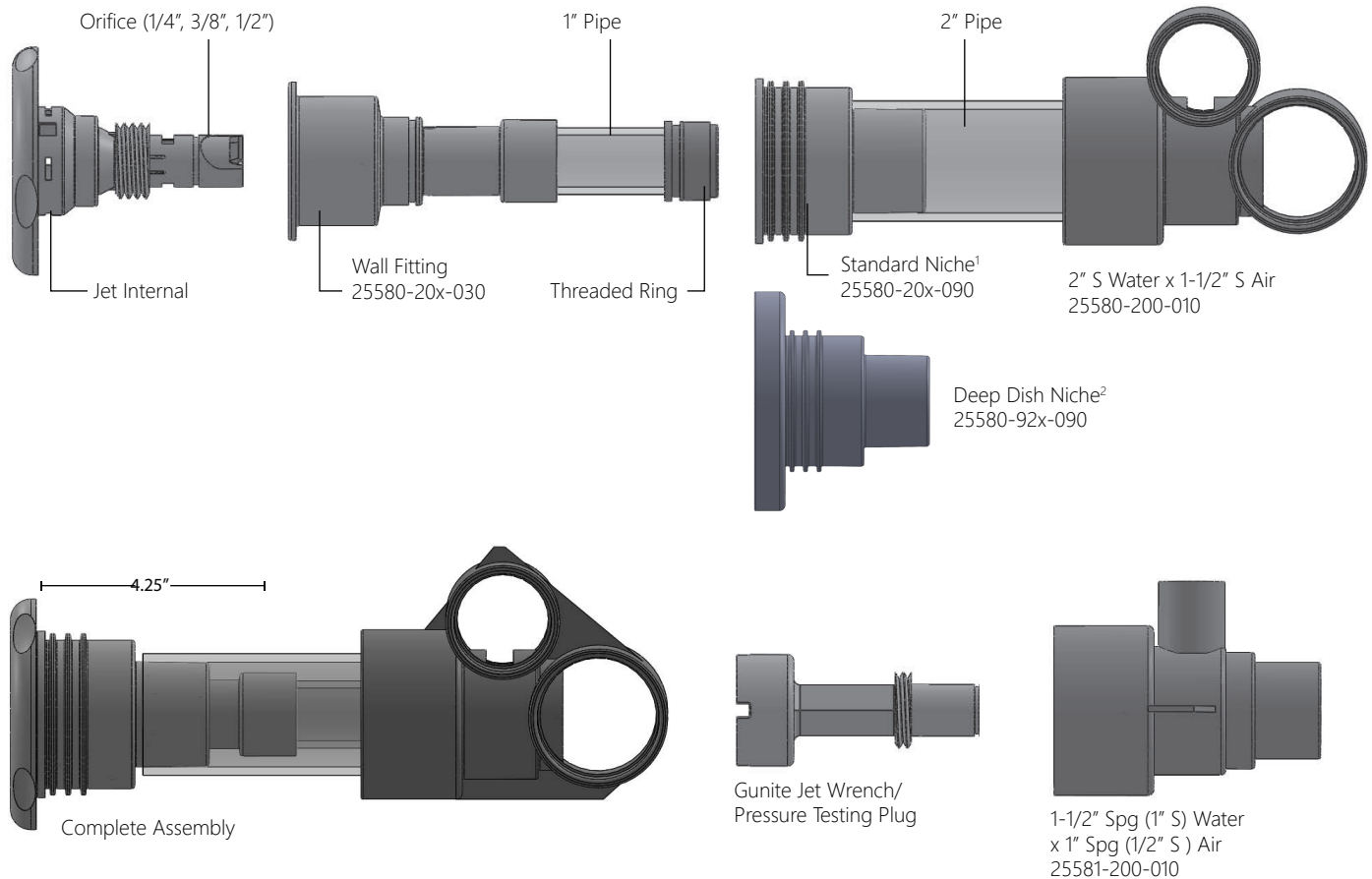

**NOTE:** Distance between the end of the Niche and the 1" PVC pipe must be 4.4"

<sup>1</sup>standard niche only included with P/N 25580-290, 25581-290 <sup>2</sup>deep dish niche sold separately

## INSTALLATION NOTES & TROUBLESHOOTING

### ADJUSTABLE TO NON-ADJUSTABLE FLOW

All 2" gunite jet internals are adjustable flow. For non-adjustable applications, remove the butterfly (Fig 1). This will convert the insert for non-adjustable installations.

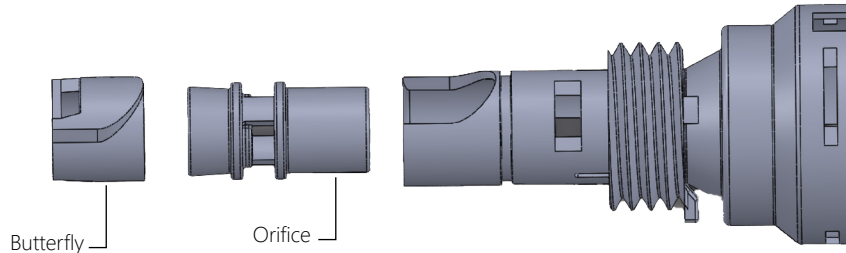

Figure 1

### AERATION TROUBLESHOOTING

If not aerating, apply Teflon tape to the 1" Threaded Ring and reinstall. If it still doesn't work, take the 1" pipe out and see if the Teflon tape is crushed. If the tape has not been crushed, the pipe has been cut too short.

### FLOW RATE AT THE 15PSI IN GPM\*

| Internal Type        | Orifice Opening |      |      |
|----------------------|-----------------|------|------|
|                      | 1/4"            | 3/8" | 1/2" |
| Directional / VTX    | 7.2             | 14.1 | 24.4 |
| Single / Double Roto | 8.3             | 14   | 24.6 |
| Massage**            | 7.2             | 14.4 | x    |

\*For more flow rate data, visit [www.c-m-p.com](http://www.c-m-p.com)

\*\*1/2" Orifice does not work with massage internal

### JET INTERNAL REFERENCE

#### COLOR OPTIONS (x)

- 0 = Stainless Steel/White
- 1 = Stainless Steel/Gray
- 4 = Stainless Steel/Black

