

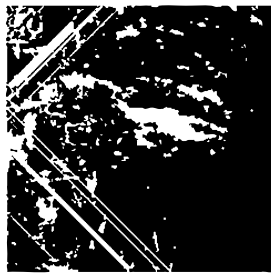

# AUTO IGNITER

## INSTALLATION & OPERATION INSTRUCTIONS

SAVE THESE INSTRUCTIONS FOR FUTURE REFERENCE



# bobé

## WATER & FIRE FEATURES

### **IMPORTANT SAFETY INFORMATION: READ AND FOLLOW ALL INSTRUCTIONS**

Save these instructions. Leave manual with homeowner after installation.

Improper installation, adjustment, alteration, service, or lack of maintenance can cause injury or property damage. Read the installation, operating, & maintenance instructions thoroughly before installing or servicing this equipment.

# IMPORTANT WARNINGS & SAFETY INSTRUCTIONS

## READ AND FOLLOW ALL INSTRUCTIONS



### WARNING

Do not store or use gasoline or flammable vapors and liquids in vicinity of this appliance. Do not install this appliance near any combustibles. A Liquid Propane cylinder not connected for use shall not be stored in the vicinity of this or any other appliance.



### WARNING

For outdoor use only. Product is not intended to be a starter for wood or any other combustibles.



### WARNING

Installation must be performed by a licensed professional. Improper installation, adjustment, alteration, service or maintenance can cause injury or property damage. Installer must follow all local codes as well as National Fuel Gas Code, ANSI Z223.1.



### CAUTION

If you smell gas, shut off the gas to the appliance and extinguish any open flame. If the odor lingers keep away from appliance and immediately call gas supplier or fire department. Do not leave any flame unsupervised.



### DANGER

Carbon Monoxide Hazard: This appliance can produce carbon monoxide which has no odor. Using it in an enclosed space can cause serious injury or death. Never use this appliance in an enclosed space such as a camper, tent, car or home.



### CAUTION

HOT! DO NOT TOUCH. SEVERE BURNS MAY RESULT. CLOTHING IGNITION MAY RESULT. Glass and other surfaces are hot during operation and cool-down. CAREFULLY SUPERVISE children near this appliance. Alert children and adults to hazards of high temperatures.

SAVE THESE INSTRUCTIONS

## ADHERE TO ALL LOCAL CODES CONCERNING INSTALLATION AND OPERATION.

- Test for gas leaks prior to use.
- Verify correct gas fuel type. Never use an alternative fuel, including bio-fuel, ethanol, lighter fluid or any other fuel.
- Installation must be performed by licensed gas piping professional.
- When pit is not in use, turn off gas and/or power to prevent unwanted start-up.
- The use of a cover when not in operation is recommended.
- Verify gas shut off is located outside of the fire enclosure. The gas shutoff should NOT be used to adjust flame height.
- An approved gas valve or keyed valve shall be installed upstream of the unit and located in an accessible area that is within 5ft from the unit.

### NOTICE

It is CRITICAL that all LP units are checked for back pressure after media has been installed.



### WARNING

Do not modify units from factory configuration. Doing so will void the warranty.

### NOTICE

Manufacturer is not responsible for damage due to improper installation.

## B. SYSTEM REQUIREMENTS

Installation must be performed by a licensed contractor. Installer must follow all local codes as well as National Fuel Gas Code, ANSI Z223.1. We suggest that our products be serviced annually by a professional certified in the US by the National Fireplace Institute (NFI) as NFI Gas Specialists or in Canada by WETT (Wood Energy Technical Training). Installer must follow all instructions carefully to ensure proper performance and safety.

### NOTICE

This Product is for outdoor use only.



### WARNING

Do not modify units from factory configuration. Doing so will void the warranty.

## GAS REQUIREMENTS

PERFECT FLAME™ FIRE RING BURNERS		
SIZE	FEMALE THREADED INLET SIZE	BTU
22" FIRE RING	3/4"	254 K
29" FIRE RING	3/4"	340 K
35" FIRE RING	3/4"	365 K

PERFECT FLAME™ FIRE LINE BURNERS		
SIZE	FEMALE THREADED INLET SIZE	BTU
35" FIRE LINE	1/2"	95 K
48" FIRE LINE	1/2"	105 K
61" FIRE LINE	1/2"	115 K
74" FIRE LINE	1/2"	125 K
87" FIRE LINE	1/2"	135 K
113" FIRE LINE	1/2"	165 K
126" FIRE LINE	TWO, 1/2"	240 K

RECOMMENDED GAS PRESSURE	
DESCRIPTION	WATER COLUMN
LIQUID PROPANE	8.5 - 11" WC
NATURAL GAS	3.5 - 7" WC

NOTE: CHECK WITH YOUR GAS SUPPLIER TO VERIFY GAS FLOWS AND PRESSURES AVAILABLE AT THE LOCATION OF YOUR INSTALLATION. IN MANY CASES UTILITY COMPANIES WILL INSTALL LARGER METERS AT NO CHARGE TO ACCOMMODATE LARGER FLOWS.

## ELECTRICAL REQUIREMENTS

- Auto ignition requires minimum 12.6 volts DC, up to 36 Volts DC at the transformer
- The included transformer steps down to 12.6 V DC
- Installer should check voltage after installation to ensure proper values

# C. AUTO IGNITER INSTALLATION

## 1. AUTO IGNITION COMPONENTS

- Auto Ignition Black Box: all gas and electrical connections are on the box.
- Transformer: A 12.6 Volt DC transformer is pre-installed.
- Probes: two probes connect to the side of the box with a quick connector. There are two probes: one for thermocouple temp sensor and one igniter.
- Other Items
  - Air mixer: included Liquid Propane units
  - Pressure regulator
  - Shut-off valve: not included

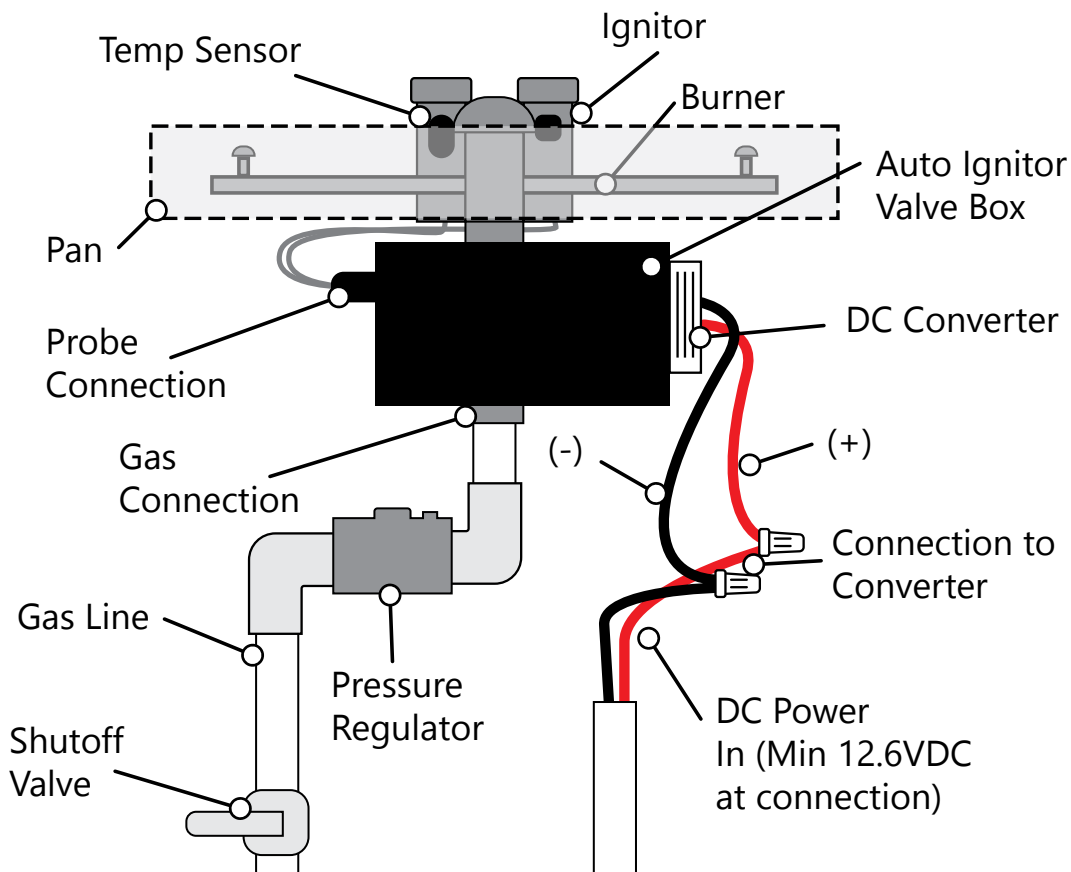

FIGURE 1: COMPLETE AUTO IGNITION SYSTEM

## 2. IMPORTANT INFORMATION FOR PROPANE UNITS

- Air mixers required for Liquid Propane.
- No elbows immediately after an air mixer. Do not attach the air mixer directly to the fire ring.
- Our units are NOT intended to be used with small portable LP tanks.
- For the air mixer, be sure to follow specific instructions and make sure the gas is flowing in the same direction as the arrow on the air mixer. Failure to do so could result in personal injury and damage to unit/property.

## C. AUTO IGNITER INSTALLATION

- Vent collars should not be obstructed.
- Air intake holes on the air mixer should not be obstructed.

### 3. GAS CONNECTION

- Before beginning, ensure the gas line is turned OFF.
- NOTE: The air mixer must be installed to use liquid propane. The “holes” on the air mixer should always face DOWN, away from the burner and pan. The air mixer should be installed immediately below the burner. (FIG 2)
- Run 1/2” gas line to the bottom connection on the black box
- Use pipe dope/joint compound on ALL threaded fittings EXCEPT flared fittings.
- Keep pipe length and elbows to a minimum to eliminate unnecessary pressure drops.
- The use of a corrugated gas line can cause unwanted noise.
- Connect pressure regulator in line before the Auto Ignitor Box. The regulator should be installed horizontally. The directional arrow should point away from the gas source and towards the gas valve.
- Confirm no more than 1/2 PSI on at the regulator inlet. If pressure is too high regulator will shut off gas flow. If above 1/2 PSI you can install a second regulator to reduce the pressure to 1/2 PSI before the included regulator.
- Verify all gas connections are tightened securely. ALWAYS perform leak tests and make repairs as needed.
- DO NOT daisy chain the gas lines. (See Section D)
- A shut-off valve must be installed at each fire feature or valve. The primary gas valve must be located where they can be easily accessible so that the gas can be shut off quickly in case of an emergency.

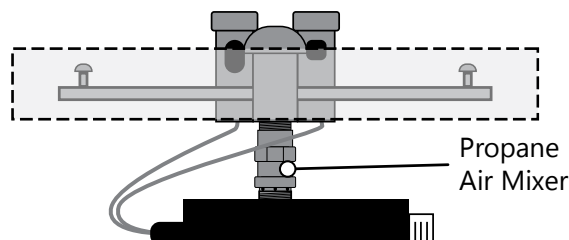

FIGURE 2: AIR MIXER LOCATION

### 4. ELECTRICAL CONNECTION

- Power Requirements
  - Auto ignition requires minimum 12.6 Volts DC, up to 36 Volts DC at the DC Converter.
  - The included transformer steps down to 12.6 V DC
  - Installer should check voltage after installation to ensure proper values
- Connections
  - There are two wire connections on the side of the black box at the transformer. Connect to power source using wire nuts.
  - These are DC power connections. You must match polarity when connecting. Connect red wire to red wire and black wire to black or blue wire.
  - Wrap wire nuts with electrical tape or some means to prevent moisture from getting in. Make sure wire nuts are positioned away from the bottom of the burner assembly.
  - Connect ground from incoming power to ground lug (If required by local codes)
  - Do not “daisy chain” electrical lines (See Section D)

## C. AUTO IGNITER INSTALLATION

### 4. CHECK SYSTEM

- a. Perform all above listed safety checks before start up. Before operating smell all around the appliance area for gas odors and next to the floor because some gases are heavier than air and will settle on the floor.
- b. Ensure any person standing close to the fire feature is aware you will be turning the fire feature on prior to actually turning it on.
- c. Turn on the unit at the switch or control panel. The igniter should start glowing followed shortly by the gas valve opening and fire igniting.
- d. Allow the unit to run for approximately five minutes then turn off.
- e. Allow to cool down for approximately three minutes before trying to re-start. As a safety feature, the thermocouple will not allow the unit to re-fire until it has cooled down.
- f. To adjust flame height, remove the silver cap on the regulator and rotate white plastic adjuster up or down. This will adjust the water column up or down

## D. OPERATION & MAINTENANCE

### 1. GLASS OR ROCK FILL MEDIA

- Use only approved fire glass or rock media on burners.
- For LP applications, use NO MORE than 1/2" of coverage on top of burner.
- Media must not cover up the holes on the side of the temp sensor, otherwise the auto ignition will not work properly. (FIG 3)

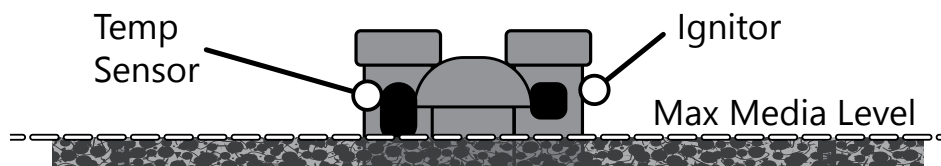

FIGURE 3: GLASS AND ROCK LEVEL

### 2. BURNER SETUP

- Prior to turning appliance on visually inspect fire feature to ensure debris such as leaves or other combustible material has not collected inside the feature which could burn and emit embers once the fire feature is turned on. Each burner should have a flame height of approximately 12" – 15" from the top of the pan.
- Each burner should be adjusted as required so that the flame size at each burner is similar in appearance to each other.
- Install decorative rock or glass on top of the "burner support" and burner assembly. Do not completely cover/obstruct the burner.

### 3. START UP

- g. Perform all above listed safety checks before start up. Before operating smell all around the appliance area for gas

## D. OPERATION & MAINTENANCE

odors and next to the floor because some gases are heavier than air and will settle on the floor.

- h. Ensure any person standing close to the fire feature is aware you will be turning the fire feature on prior to actually turning it on.
- i. Turn on the unit at the switch or control panel. The igniter should start glowing followed shortly by the gas valve opening and fire igniting.
- j. If the unit does not light the first time, there may be air in the gas line. Turn off unit and allow to sit for 30 seconds the power back on. This could potentially take two-three cycles but then should fire consistently.

## 4. MAINTENANCE & CARE

- Periodically clean the burner assembly with a wet cloth or cleaning solution to remove carbon build-up. Frequency of the cleaning will depend on usage.
- Periodically inspect the underside of the burner assembly for any signs of excessive temperatures.
- Keep the ignition and temperature probe locations clear of media or debris.
- Check that all gas connections are tight.
- The burner assembly should be covered and protected from snow and ice. The burner should not be operated in high wind conditions.
- Visually inspect burner holes for debris/insect infestation Clean burners as necessary using compressed air.
- Use the system! If the feature has been inactive for an extended period, turn fire feature on to ensure proper operation.
- Inspect the gas line regularly. If the line shows evidence of excessive abrasion or wear or if the line is damaged, it must be replaced before use.
- Inspect the burner before each use of the appliance. If there is any evidence that the burner is damaged, it must be replaced before operating.
- If any repairs are required, contact a licensed professional.

### COMMON ISSUES/MISTAKES

- Check line connections - do not daisy chain gas or electrical connections (see Section C)

## E. TROUBLESHOOTING

- Check gas pressure for natural gas and propane (see Section B)
  - If using with propane gas - ONLY use with air mixer correctly installed. (See Fig 2) ½ " air mixer for propane includes stamped marking for gas flow direction. Air mixer is not required with Natural Gas.
  - Check electrical voltage. Minimum volts at the transformer connection is 12.6 VDC.
  - Check electrical connections. Auto ignitor uses DC power. Connect positive/red to positive/red/brown and negative/black to negative/black/blue.
  - Check ground connections. (if required)
  - Upon completing the gas line connection, a small amount of air will be in the lines. When first lighting the burner, it will take a few minutes for the lines to purge themselves of this air. Subsequent lighting of the appliance should not require such purging.
- c. LED Indicators
1. There are three LED indicators on the side of the valve next to the probe connection
  2. The LED indicators are an obsolete component and can be disregarded

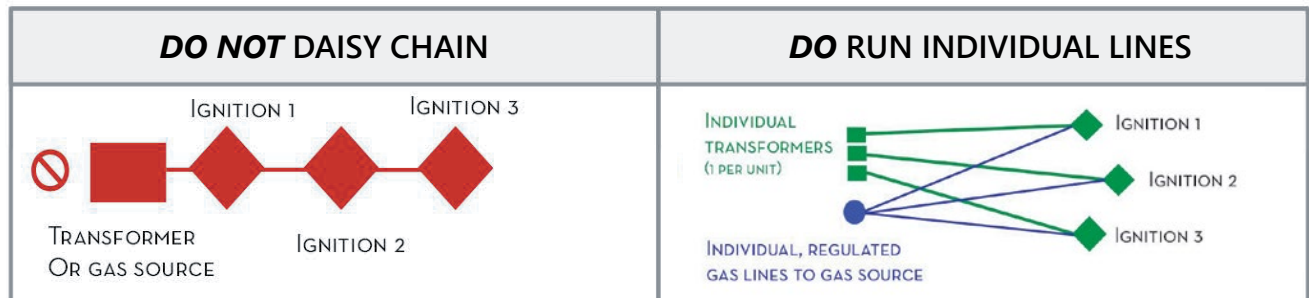

FIGURE 5: DAISY CHAIN GUIDE

### HOW TO PERFORM A LEAK TEST

- a. Prepare a leak testing solution of soapy water by mixing in a spray bottle one part liquid soap to one part water.
- b. Make sure all the control knobs are in the OFF position.
- c. Turn on the gas.
- d. Apply the leak-testing solution by spraying it on joints of the gas delivery system. Blowing bubbles in the soap solution indicates that a leak is present.
- e. Stop a leak by tightening the loose joint or by replacing the faulty part with a replacement part recommended by the manufacturer.
- f. Turn the control knob back to the full OFF position.
- g. **If you are unable to stop a leak:** Please consult a gas specialist. Shut off the gas supply to the fire pit and release pressure in the hose and manifold. Call/consult an authorized gas appliance service technician or an liquid propane gas dealer. Do NOT use the appliance until the leak is corrected.

Perform a leak test at least once a year whether the gas supply has been disconnected or not. Whenever any part of the gas system is disconnected or replaced, perform a leak test. As a safety precaution, remember to always leak test your fire pit outdoors in a well-ventilated area. Never smoke or permit sources of ignition in the area while doing a leak test. Do not use a flame, such as a lighted match to test for leaks.



## E. TROUBLESHOOTING

SITUATION	POSSIBLE CAUSE	CORRECTIVE ACTION
<b>System will not light</b>	Air in gas line	On a new install, it may take multiple attempts to completely purge air. On an existing install, check for leaks.
	Debris in gas line	Confirm gas line is clear (insulation, dirt, plastic, excessive pipe sealer etc..)
	Incorrect gas pressure	Confirm proper gas pressures. Check for leaks. A regulator must be installed at each burner.
<b>System will not light / will not stay lit</b>	Incorrect gas pressure	Confirm proper gas pressures. Check for leaks.
	Improperly Applied Media	Remove excess media and attempt to relight
	Incorrect Voltage	Connection at transformer must be minimum 12. VDC
	Incorrect Electrical Connections	Connections are DC, confirm positive and negative wires are connected correctly.
<b>LED indicators do not come on when the system has power</b>	N/A - The LED indicators are an old component that are not used in the latest revision to the auto igniter and can be disregarded.	N/A
<b>System with propane does not burn correctly / is very black / produces a lot of soot.</b>	Lack of ventillation will cause improper burning or failure	Confirm air mixer is installed correctly. Check for proper ventillation, do not block an ventillation paths in the system.
	Propane source may be introducing impurities into the system	Check with your propane provider
<b>Whistling Sound</b>	Corrugated gas line used for installation	Use whistle free hose - Adjust hose to create the path of least resistance for gas.
		Install optional gas muffler to reduce whistling noises. Depending on your installation a muffler may not completely remove all gas whistling





## SAVE THESE INSTRUCTIONS

**Record Information on this System Below & Keep for Your Records**

Installer \_\_\_\_\_

System Purchased From \_\_\_\_\_

Installation Date \_\_\_\_\_

Serial Number \_\_\_\_\_